

CVS METAL INDUSTRIES SDN BHD

IP65

COMPLETE PRODUCT SPECIFICATIONS & DIMENSIONS

CVS-S01
Rev : 3

CR MODEL – WALL MOUNT INDUSTRIAL METAL ENCLOSURE

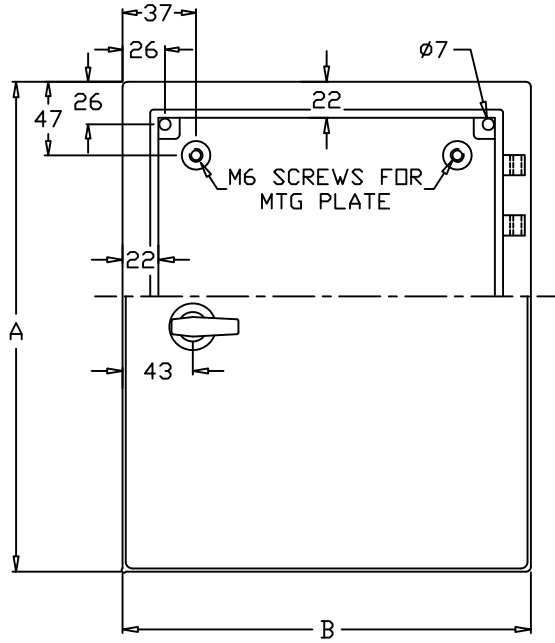

FRONT VIEW

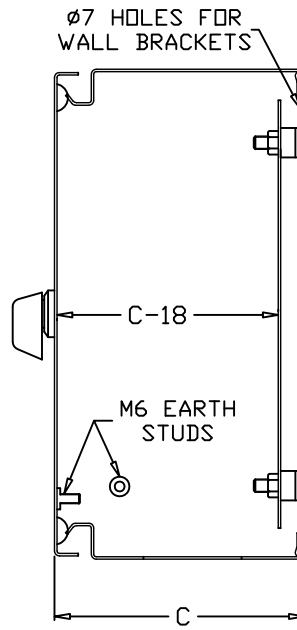

SIDE VIEW

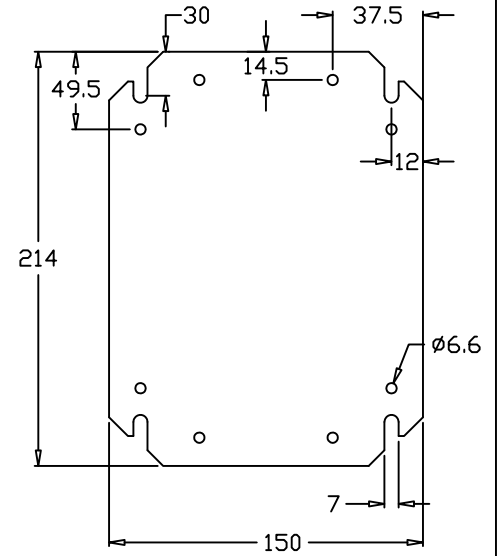

MOUNTING PLATE

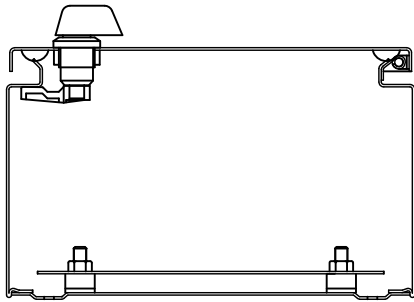

BOTTOM VIEW

CR MODEL DESCRIPTION		
PART NAME	MATERIAL	FINISHING
BODY	1.4MM M.S	POLYESTER POWDER COATING
DOOR	1.4MM M.S	RAL7032, BEIGE
MOUNTING PLATE	1.4MM M.S	RAINBOW PLATED
WALL BRACKET (OPTIONAL)	2.0MM M.S	RAINBOW PLATED

MODEL	A	B	C	GLAND OPENINGS	NO. OF WALL BRACKETS	WEIGHT (KG)
CR252010	250	200	103	0	0	3.0
CR252015	250	200	153	0	0	3.5

- NOTES: 1) MEASUREMENTS ARE IN MM
2) NO GLAND OPENING
3) WALL BRACKET NOT INCLUDED FOR THIS SIZE

CVS METAL INDUSTRIES SDN BHD

IP65

COMPLETE PRODUCT SPECIFICATIONS & DIMENSIONS

CVS-S01
Rev : 2

CR MODEL – WALL MOUNT INDUSTRIAL METAL ENCLOSURE

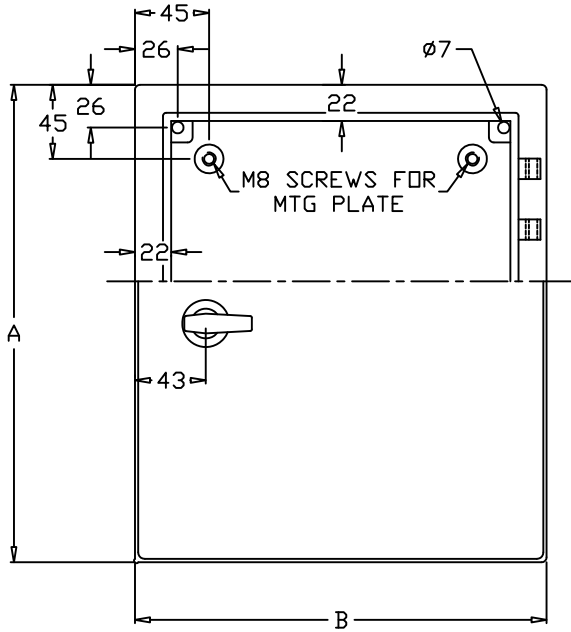

FRONT VIEW

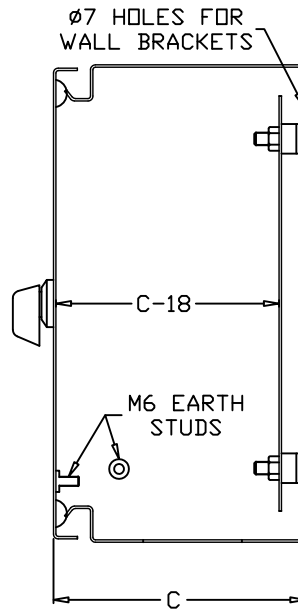

SIDE VIEW

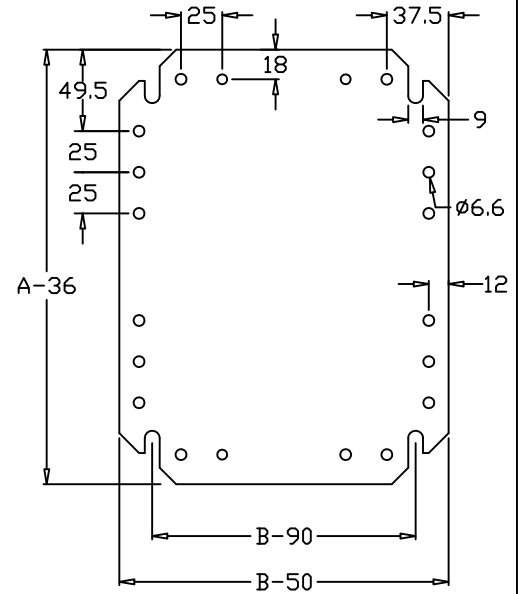

MOUNTING PLATE

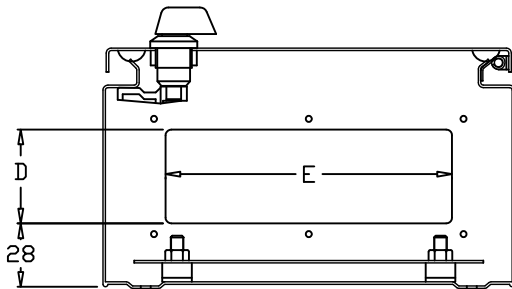

BOTTOM VIEW

CR MODEL DESCRIPTION		
PART NAME	MATERIAL	FINISHING
BODY/DOOR/GLAND PLATE	1.4MM M.S	POLYESTER POWDER COATING – RAL 7032, BEIGE
MOUNTING PLATE WALL BRACKET	1.4/2.0MM M.S 2.0MM M.S	RAINBOW PLATED

MODEL	A	B	C	D	E	MOUNTING PL. THICKNESS	BOT. GLAND TYPE	WALL BRACKETS	WEIGHT (KG)
CR302515	300	250	153	60	174	1.4	A1	4	5.4
CR302520	300	250	203	60	174	1.4	A1	4	6.0
CR303015	300	300	153	60	174	1.4	A1	4	6.0
CR303020	300	300	203	60	174	1.4	A1	4	6.8
CR403015	400	300	153	60	174	2.0	A1	4	8.0
CR403020	400	300	203	60	174	2.0	A1	4	8.4
CR404020	400	400	203	88	259	2.0	B1	4	10.6
CR504015	500	400	153	60	174	2.0	A1	4	11.8
CR504020	500	400	203	88	259	2.0	B1	4	13.0
CR504025	500	400	253	88	259	2.0	B1	4	14.0
CR504030	500	400	303	88	259	2.0	B1	4	15.0
CR505020	500	500	203	88	259	2.0	B1	4	15.2
CR505025	500	500	253	115	310	2.0	C1	4	16.6

NOTES: 1) MEASUREMENTS ARE IN MM
2) SINGLE GLAND OPENING ON BOTTOM

CVS METAL INDUSTRIES SDN BHD

IP65

COMPLETE PRODUCT SPECIFICATIONS & DIMENSIONS

CVS-S01
Rev : 0

CR MODEL – WALL MOUNT INDUSTRIAL METAL ENCLOSURE

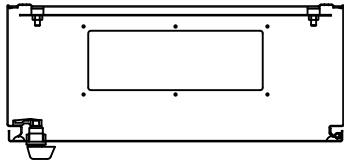

TOP VIEW

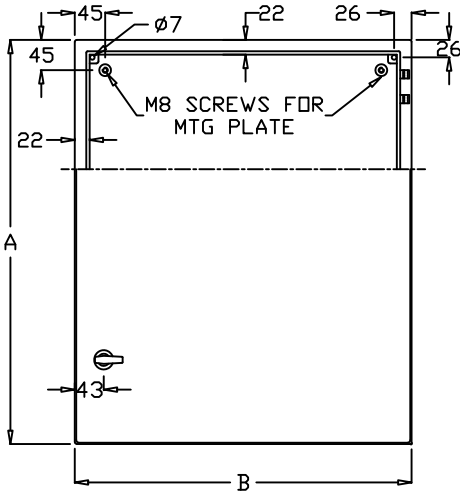

FRONT VIEW

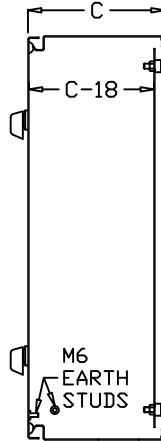

SIDE VIEW

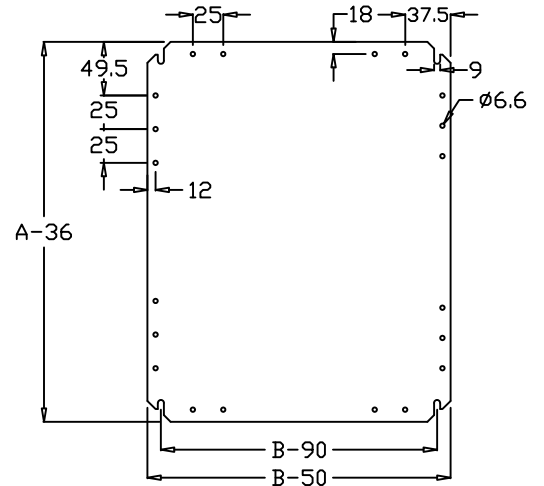

MOUNTING PLATE

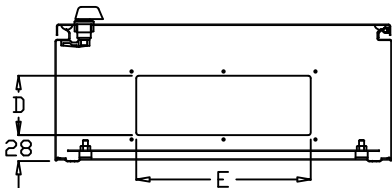

BOTTOM VIEW

CR MODEL DESCRIPTION		
PART NAME	MATERIAL	FINISHING
BODY/GLAND PLATE	1.4MM M.S	POLYESTER POWDER
DOOR	1.4/2.0MM M.S	COATING- RAL7032, BEIGE
MOUNTING PLATE	2.0MM M.S	RAINBOW PLATED
WALL BRACKET	3.0MM M.S	

MODEL	A	B	C	D	E	DOOR THICKNESS	TOP & BOT. GLAND TYPE	WALL BRACKETS	WEIGHT (KG)
CR604015	600	400	153	60	174	1.4	A2	4	14.2
CR604020	600	400	203	88	259	1.4	B2	4	15.2
CR604025	600	400	253	88	259	1.4	B2	4	15.2
CR605020	600	500	203	88	259	2.0	B2	4	19.7
CR605025	600	500	253	115	310	2.0	C2	4	21.0
CR606020	600	600	203	115	310	2.0	C2	4	23.0
CR606025	600	600	253	115	310	2.0	C2	4	24.6
CR606030	600	600	303	115	310	2.0	C2	4	27.0
CR705020	700	500	203	88	259	2.0	B2	4	22.0
CR705025	700	500	253	115	310	2.0	C2	4	23.6
CR806020	800	600	203	115	310	2.0	C2	4	29.0
CR806025	800	600	253	115	310	2.0	C2	4	30.6
CR806030	800	600	303	115	310	2.0	C2	4	32.0
CR1006030	1000	600	303	115	310	2.0	C2	4	39.0

- NOTES: 1) MEASUREMENTS ARE IN MM
 2) SINGLE GLAND OPENING ON TOP & BOTTOM
 3) ALL WALL BRACKETS ARE 3.0MM EXCEPT CR 604015 - 2.0MM

CVS METAL INDUSTRIES SDN BHD

IP65

COMPLETE PRODUCT SPECIFICATIONS & DIMENSIONS

CVS-S01
Rev : 0

CR MODEL – WALL MOUNT INDUSTRIAL METAL ENCLOSURE

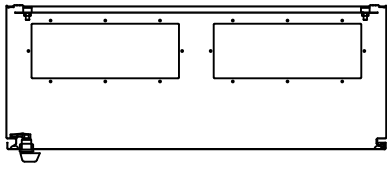

TOP VIEW

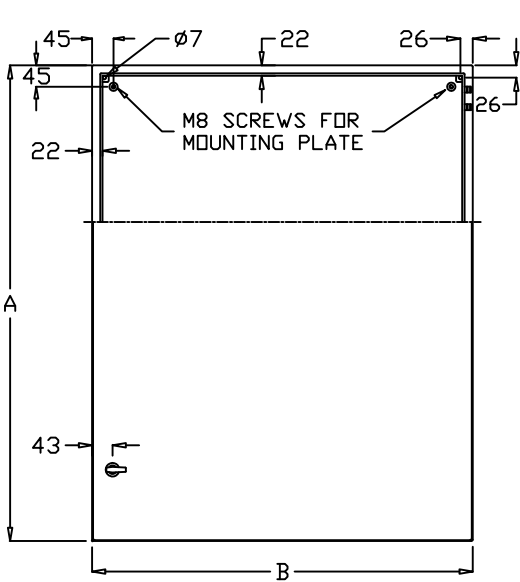

FRONT VIEW

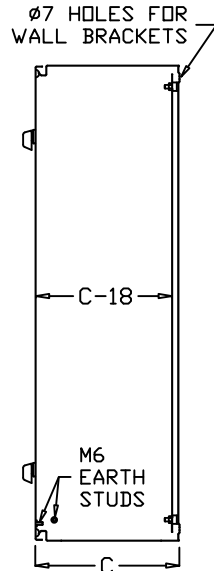

SIDE VIEW

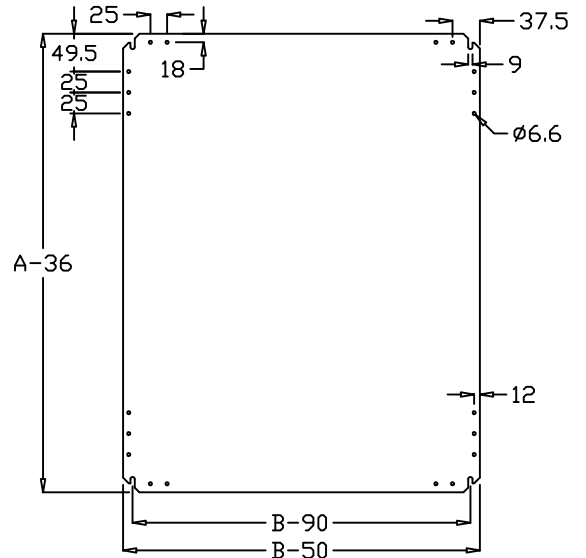

MOUNTING PLATE

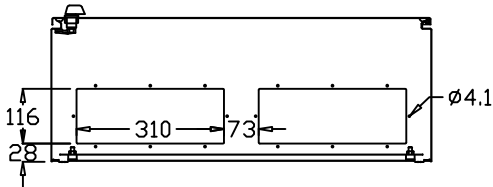

BOTTOM VIEW

CR MODEL DESCRIPTION		
PART NAME	MATERIAL	FINISHING
BODY/GLAND PLATE	1.4MM M.S	POLYESTER POWDER COATING
DOOR	2.0MM M.S	RAL7032, BEIGE
MOUNTING PLATE	2.0MM M.S	RAINBOW PLATED
WALL BRACKET	3.0MM M.S	

MODEL	A	B	C	TOP & BOTTOM GLAND TYPE	WALL BRACKETS	WEIGHT (KG)
CR808025	800	800	253	C4	4	39.5
CR1008030	1000	800	303	C4	4	50.0
CR1208030	1200	800	303	C4	4	58.5

NOTES: 1) MEASUREMENTS ARE IN MM
2) DOUBLE GLAND OPENINGS ON TOP & BOTTOM

SPECIFICATIONS & DIMENSIONS
TWO DOOR ENCLOSURE

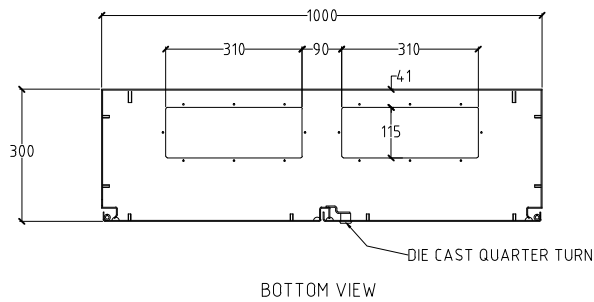
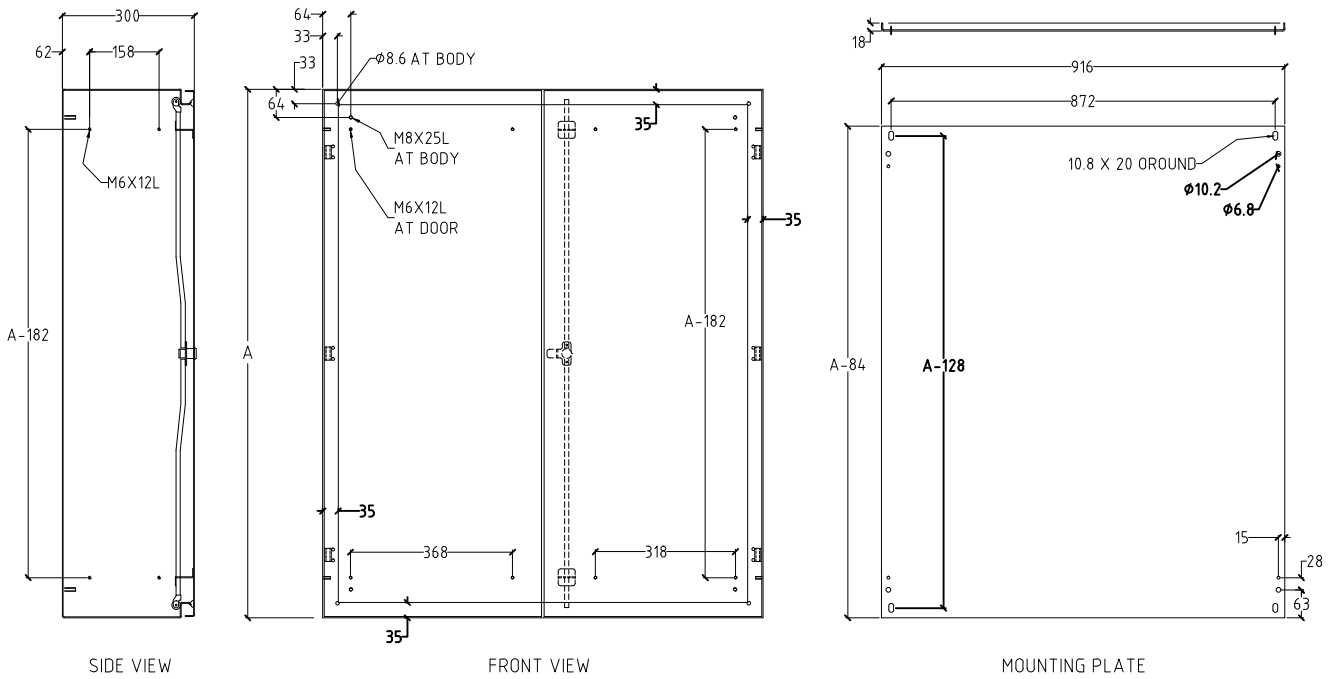

CANOPY

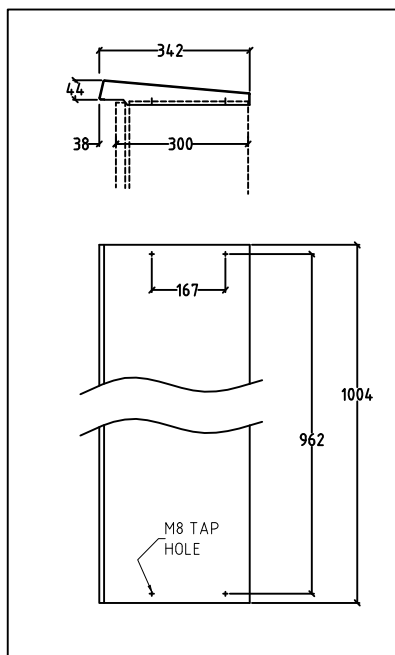

CANOPY

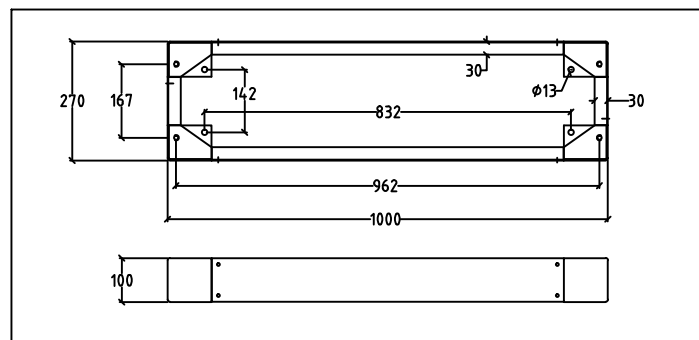

TWO DOOR ENCLOSURE	
TYPE	A
CR1008030H	800
CR10010030	1000
CR12010030	1200

PART NAME	MATERIAL	FINISHING
BODY/DOOR	2MM CR	RAL 7032 POLYESTER COATED
GLAND PLATE	1.5MM CR	RAL 7032 POLYESTER COATED
M. PLATE	2.5MM GI	ORIGINAL
CANOPY	1.5MM EG	RAL 7032 POLYESTER COATED
PLINTH	2/3MM CR	BLACK POLYESTER COATED